



**TESTING**

**PULSE MONITOR TRIP**

Jack the drive wheels up and operate the control in SCR range. Using an insulated tool, manually close the 1A contactor, and the PMT card should operate. If the PMT card fails to operate, check all wiring to the PMT card.

If all tests are good and the PMT section fails to operate, replace the card.

**STATIC RETURN TO OFF**

Open the seat switch.

Move the control handle to forward or reverse position.

Close the seat switch or late-opening brake switch, and also close the accelerator start or early-opening brake switch. The contactor should not close.

Return the control handle to off and then return the handle to forward or reverse position. The contactor should close.

If the SRO section fails to operate, check all the wiring to the PMT card. If all tests are good and the SRO section fails to operate, replace the card.

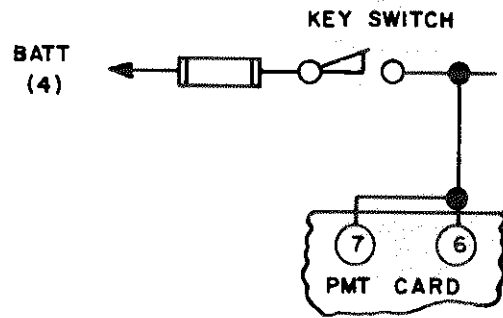

Fig. 3A. Key switch reset

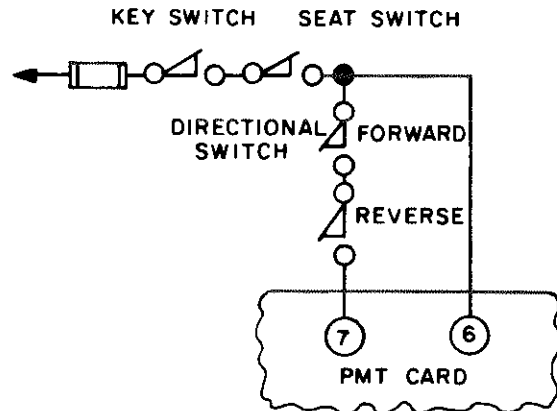

Fig. 3B. Static return to off

**GENERAL ELECTRIC COMPANY  
INDUSTRIAL CONTROL PRODUCTS DEPARTMENT  
SALEM, VA. 24153**

